

# The CBA Gas Forge

as seen at Spring Conference  
Mark Kochan, Placerville

**Editor's Note.** You saw this in use at Spring Conference. In addition to his other duties, Mark Kochan, CBA President, took on the job of building several of these, with the help of a few other CBA members. This effort was undertaken to support CBA events. CBA offers the following information as a design guide, to be adapted to your specific needs.

Many characteristics of this forge were selected to support one of CBA's missions – to be a leader in best practices for the blacksmithing community.

Mark expressed his appreciation for the help he received from John Barron, John Emmerling and Sean Wilson in the building of these forges.



## Designing a Gas Forge

A gas forge is a tool. Selecting the right tool for your shop should be based on your individual requirements. The CBA-style LP gas forge is very versatile. It was designed and built to meet a specific set of requirements, including safety, flexibility and portability.

### CBA Safety Committee Requirements

- No exposed ceramic wool, Kaowool or loose ceramic insulating material. Too dangerous.
- All exposed surfaces had to be hard faced to stand up to hard use.
- It had to be as safe as we could make it.

### Portability

- Easy to store and transport. Removable legs. Electric parts mounted below the combustion area and protected.
- Two members had to be able to lift the unit to move it in and out of the trailer/storage location and to set it up.
- Durable enough to survive bouncing around in the CBA trailer.
- All attaching parts had to be protected and contained.
- Aluminum sleeves were added to protect gas hoses from hot metal.
- All breakable parts had to be available off the shelf and replaceable or easy to make.

### Flexibility

- Variable volume forge cavity. Adjustable to fit typical projects planned by CBA demonstrators.
- As safe as we could make it and still meet our heat requirement of 2350°.
- Use LP gas with air blower to lower fuel usage. Add air curtain blower to divert heat blast at front of forge opening.
- Regulators with quick disconnects with safety fuel shut off.
- Needle valve for fuel set and adjust, with in-line ball valve for visible, positive fuel shut down.
- Intuitive setup, on the off chance the included laminated setup instructions are lost. Backup sheets kept in trailer.

# CBA Gas Forge

The basic forge looks like a low table with bricks on top. Under the bricks the two blowers are mounted.

Never remove the table bricks without wearing a protective dust mask. Always replace a damaged brick with a brick of the same exact specifications.

The fixed leg sockets protect the blowers from touching the floor when the 42" legs are removed.

All of the attaching parts, except the removable legs, pack down into a plastic tub with a snap-on lid for transport.

The top surface of the firebricks measures 18" x 18".

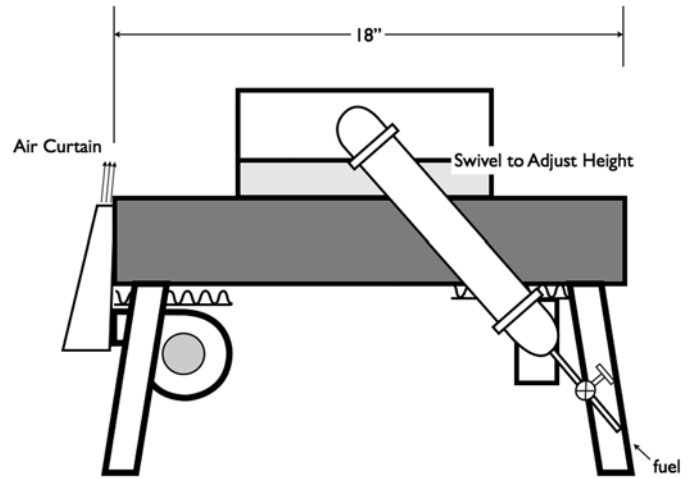
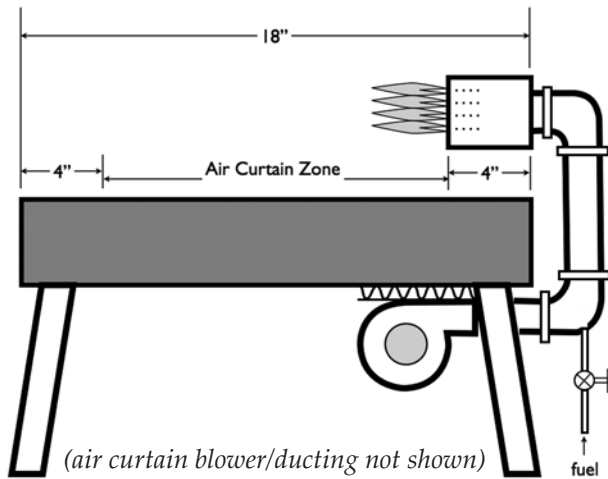
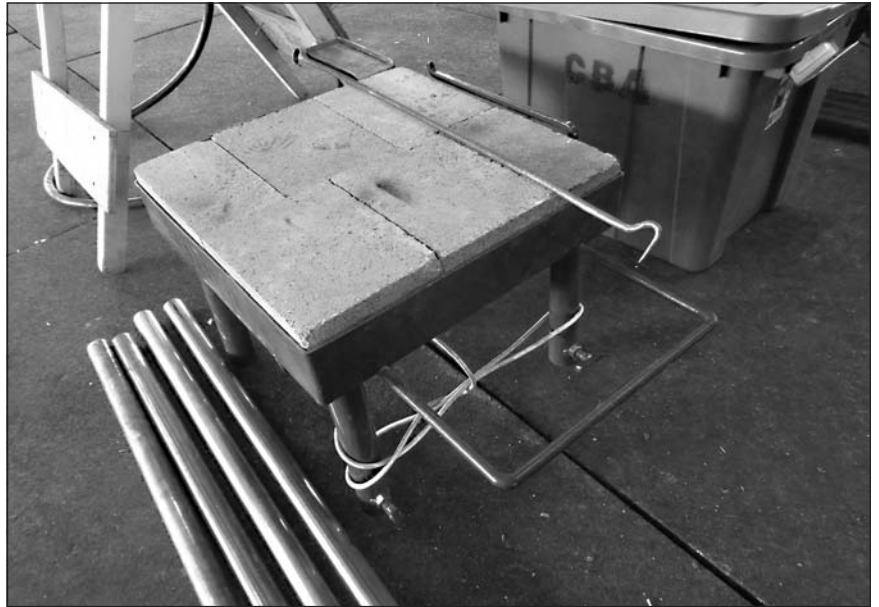

## Firebricks

The bricks are the most important component. The Clipper DP brick from Harbison Walker is rated at over 2600°. They fit the 1/4" plate deck area in a specific pattern. Position them and build around the shape you choose.

## Cast Blocks (top sections)

The large cast blocks are made of KAST-O-LITE® 30 from Harbison Walker in Richmond, California. They need to be stored vertically to protect from damage.

**NOTE.** An expanded *Director's Cut* of this article begins on page 5.

# CBA Gas Forge

## Burner

The burner is a ribbon burner, based on John Emmerling's article originally published in 2006 in the *Hammer's Blow*. You can also find his article by searching on the internet. An inch and a half was added to the height of the burner forms to make the burner the same height as the bricks used.

The burner is cast from Mizzou Castable refractory, from Harbison Walker.

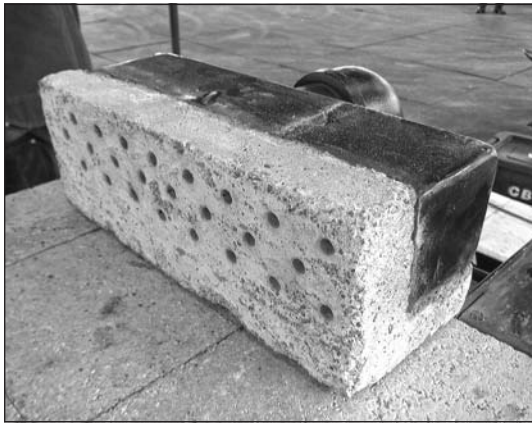

## Flow Path

The forge has two blowers, one to power the air curtain – for keeping stock cooler – and one supporting the ribbon burner.

In the picture at top right, the air curtain is on the left edge of the picture. The blower supporting the burner is in the lower center of the picture.

The burner is connected to the main blower with 2" pipe. It does not get hot, so you can use either black iron or galvanized.

To make the burner removable, a slide on-ring and spacer was forged to adapt to the 2" pipe and the blower with a snug fit to minimize air loss. The LP gas is injected into the 2" pipe at the first elbow as it leaves the blower. A 3/8" black pipe with about 1/4" interior was used for gas flow. Unlike atmospheric forge nozzles, there is no small injector nozzle – just the 1/4" gas pipe opening.

*You must always have the blowers on and flowing* before you have gas flowing into the 2" pipe. The blower blends the air blast with the LP gas as it pushes it through about 18" of pipe in the direction of the ribbon burner to be ignited.

# CBA Gas Forge

## Blower Details

The air curtain uses a 134 cfm squirrel cage blower, the same as the CBA coal forges. The main burner blower is a Sunlar 125 cfm blower. When combined with propane gas, it puts out more than enough heat – 2325° for 45 minutes was the longest test. Both blowers turn on at the same time.

## Door

A brick of KAST-O-LITE 30 with a handle was made as a forge door. Greg Hudgins suggested adding a small table to support the fully open door. Always keep an opening at the front or back to allow the blower to vent.

## Construction

Make certain the mounting tubes for the legs are long enough to protect your blower from hitting the floor. (*Adjust height to your needs.*) The legs used are 42" and they slide into the mounting tubes all the way up to the 1/4" plate. Set the mounting tubes out at a slight angle for better stability. Make a jig so that they weld in the same position. One inch of ceramic wool under the bricks will minimize heat transfer to the electric parts. Make certain it is totally contained. Handles formed from 1/2" round stock make moving the deck easier. Wiring the two blowers together into a small electrical box gives you a place to put a switch and an extra outlet.



Keep in mind, almost all of the parts you will be needing are usually made for some other purpose. It is up to you to determine if they are safe to use in your plan. This forge build was planned around parts that are available commercially, and that determined the size and shape that were used. If requested, part numbers and suppliers can be provided.

Keep in mind, almost all of the parts you will be needing are usually made for some other purpose. It is up to you to determine if they are safe to use in your plan. This forge build was planned around parts that are available commercially, and that determined the size and shape that were used. If requested, part numbers and suppliers can be provided.

## Setup & Operation

Every time the forge is set up, all the parts must be visible so that they can be inspected for damage. There are instructions on laminated sheets that are kept with the forges in the blue storage tubs.

Two CBA members are required to lift and move the forge deck and the parts containers. Always move the forge decks and containers in the working orientation. Never tip or allow the blowers to touch or rest on an uneven or hard surface that could damage the blowers.

Use a powerful, dependable lighter such as a Bernzomatic TS 4000T Trigger Start Torch Head (included in kit).

These forges will provide heat in excess of 2400°. 2000° is hot enough. You should be aware of the heat required for your project. To determine how hot the forge is burning, the education team should periodically test and reset the needle valve to about 2000°. To use this forge efficiently, each smith must stay alert to the look of the flame, the sound of the roar and how quickly the metal reaches a working heat. Users must be aware if it is getting too hot and wasting gas or too cool and heats are taking too long. It is critical to change the settings accordingly. Sudden changes in forge temperature indicate problems. Dropping temperature usually indicates gas flow restriction such as regulator freeze-up. Sudden flare-up with yellow flame may indicate a power outage. Situational awareness is required. ♣

# CBA Gas Forge ~ Director's Cut

## General Considerations When Building a Gas Forge.

Keep in mind almost all of the parts you are going to need are usually made for some other purpose.

It is up to you to determine if they are safe to use in your plan. I planned this forge build around parts that were commercially available and that is how I decided what size and shape to use. If requested, I can make all the part numbers and parts suppliers available on line.

They fit the  $\frac{1}{4}$ " plate 18 x 18 deck area in a specific pattern. Position them and build around the shape you choose.

I used  $\frac{1}{8}$ " flat bar 3" wide to wrap around the  $\frac{1}{4}$ " plate deck. Tacking, heating and wrapping, I built them upside down for easy welding.

Use an extra inch or more of edge wrap material so you have enough. Trim to fit. Make certain the mounting tubes for the legs (adjust length to your needs) are long enough to protect the blower from hitting the floor. The legs used are 42" and they slide into the mounting tubes all the way up to the  $\frac{1}{4}$ " plate. Set the mounting tubes out at a slight angle for better stability. Make a jig so that they weld in the same position. 1" of ceramic wool under the bricks will minimize heat transfer to the electric parts. Make certain it is totally contained. Handles formed from  $\frac{1}{2}$ " round stock make moving the deck easier.

Wiring the two blowers together into a small electrical box gives you a place to put a switch and an extra outlet. The ribbon burner plans are available on the internet. John Emmerling has a good version and easy to follow plans. I added  $1\frac{1}{2}$ " to the height of my burner forms to make the burner the same height as the bricks I used. The burner is connected to the main blower with 2" black pipe. To make the CBA burner removable I forged a slide on ring and spacer that adapts to the 2" pipe and the blower with a snug fit to minimize air loss. The LP gas is injected into the 2" pipe at the first elbow as it leaves the blower. I used a  $\frac{3}{8}$ " black pipe with about  $\frac{1}{4}$ " interior for gas flow. Obviously you must always have the blowers on and flowing when you have gas flowing into the 2" pipe. The blower blends the air blast with the LP gas as it pushes it thru about 18" of pipe in the direction of the ribbon burner to be ignited.

The LP gas has to have the right mix of air to burn correctly. Plan the size forge needed and stack the bricks to contain the air/gas blast prior to attempting to light it up. A brick of KAST-O-LITE 30 with a handle was made as a forge door. Greg Hudgins suggested adding a small table to support the fully open door. Always keep an opening in front or back to allow the blower to vent.

## Building The CBA Gas Forge ~ Director's Cut



Mix the KAST-O-LITE 30 per the instructions on the bag. I like to use less water. Tamp it down into the casting mold and bring up any excess water. I like to line the mold with Saran Wrap® for a smooth finish.

If you want to speed up the curing you can put the packed mold in the oven at 180° for two hours.



This shot of the forge deck shows the 1/2" round handles, the tray corners, and the 3/8" opening of the air curtain.

# Building The CBA Gas Forge ~ Director's Cut



I use  $\frac{3}{4}$  spacers to position the gas diffuser in the burner and mig weld it in place.

To make the 24 orifices I switched from crayons to In & Out straws. I spray the mold with diesel fuel or WD-40.



When I mounted the blowers below the deck I countersunk the machine head screws to make them flush. I used a 5" long pipe to connect the two 2" elbows. The  $\frac{1}{4}$ " LP gas line welds into the lower elbow.



# Building The CBA Gas Forge ~ Director's Cut



After testing all the connections for leaks, turn on the blower and test the burner. A new burner will steam off excess moisture in the first 15-minute test.

Two of the assembled forges ready to test.



**Burn in at the Conference.** Notice the storage tub and with the laminated start-up instructions. ♣

*See Next Page for CBA Gas Forge Setup Instructions*



## **CBA Gas Forge Setup Instructions**

The following instructions on laminated sheets are kept with the forges in the blue storage tubs.  
Two CBA members are required to lift and move the forge deck or the parts containers.  
Always move or transport the forge decks and containers in the working orientation.  
Never tip or allow the blowers to touch or rest on an uneven or hard surface that could damage the blowers.

### **Locate All of the Forge Parts**

Burner Deck, Burner, Legs, Fuel supply, Bricks, TS 4000 Lighter.

Find and become familiar with the Ball Valve Fuel Shutoff. The brass needle valve is for fine tuning the burner and it should be preset but can be adjusted as needed.

### **Connecting Forge to Fuel**

Inspect all parts and verify that both blowers are connected and working.

A dependable source of power is very important. Avoid loose cords that may create a trip hazard.

Position gas line so it is not in a walking path. Connect regulator to LP gas supply. Verify connections.

Tank volume should be enough that will handle gas flow without freezing regulator.

Slide burner into place, secure with metal support flap to keep gas feed pipe tight on blower.

### **Brick Adjustment**

Determine the size of the forge needed for your project and adjust interior and opening as needed.

Review your plan and give yourself extra space needed to allow dimensional changes as project evolves.

Work should fit into the forge without touching the forge walls.

The bigger the forge opening the longer it takes to reach the temperature needed for your project.

The CBA forge is designed to meet most of our projects. Bigger projects may require a larger forge.

The sliding block can be used to reduce the forge opening. Hot bricks will quickly defeat the best glove.

Don't close the forge completely. Howling may result. A small gap between the bricks at the back will help.

### **Tools**

Pull and push rakes are helpful in positioning work in the forge. Removing small pieces from the forge interior, once they are in position to be grasped, can be safely done with tongs. The torch used for lighting should be kept near work area. Fire extinguishers and safety placards should be in place.

### **Setting Up the Forge at the Demo Site**

Level and stabilize the forge at the work site.

It usually takes two or three people to raise the forge high enough to install the legs.

Use a powerful dependable lighter like a Bernzomatic TS 4000T Trigger Start Torch Head. (included in kit)

1) Turn on the blower. 2) Light the handheld torch in the forge opening. 3) Turn on the gas.

**The forge should light.**

If the forge does not light turn off the gas flow immediately at the Ball Valve. Do not attempt to relight if you smell gas. Check all connections and verify gas flow. Wait several minutes until gas has cleared before attempting to relight.

### **Forge Use**

These forges will provide heat in excess of 2400°. 2000° is hot enough.

You should be aware of the heat required for your project. To determine how hot the forge is burning the Education team should periodically test and reset the needle valve to approx. 2000°. With use smiths will change the settings.

Users must be aware if it is getting too hot and wasting gas or too cool and heats are taking too long.

The look of the flame, the sound of the roar and how quickly your metal reaches a working heat are what each smith must learn to use this forge efficiently.

Sudden changes in forge temperature are an indication of problems.

Dropping temperature usually indicates gas flow restriction like regulator freeze up.

Sudden flare-up with yellow flame may indicate a power outage. Situational awareness is required.

### **Bricks**

We use precast CLIPPER® DP 3000o rated in two sizes.

The light color forge material is KAST-O-LITE 30.

Steam from new bricks or blocks is not unusual. Avoid water and sudden shock to hot bricks.

Both materials are from Harbison Walker. Store and transport bricks on edge to avoid cracking.

Allow bricks and forge to cool before disassembly.♣